

CLASS I, DIVISION 1 LIQUID-SOLID SEPARATION CENTRIFUGE

When processing flammable, hazardous or otherwise dangerous media that can adversely impact the environment, it's important to prevent it from escaping the process stream. It is equally important to prevent atmospheric oxygen from leaking into the centrifuge and creating an unsafe environment that can potentially cause an explosion or another undesirable reaction. Creating a safe atmosphere within the separation system also helps when processing materials that cannot be exposed to oxygen. In these situations, preventing oxidation is imperative to assure the quality of the final product.

In years past, these applications relied on filtration or press equipment to separate a liquid from a solid. This white paper describes a process for dewatering and separating solids using an inert gas in a technically sealed centrifuge (e.g., decanter, Tricanter® or separator).

There are three general methods for ensuring a safely sealed piece of industrial equipment:

1. Overpressure—This method is only applicable to equipment or containers that have a high degree of pressure resistance. The air inside the equipment is removed by continually adding and releasing high-pressure inert gas into the sealed equipment. This is repeated until the oxygen concentration inside the equipment is at a desired level. Once in operation,

the equipment is kept at a higher differential pressure than the atmosphere; however, this pressure is much lower than what is used during inertization.

2. Vacuum – Here all air is removed from the interior by creating a vacuum. As soon as the vacuum is accomplished, the equipment is filled with inert gas to ensure an inert atmosphere during operation. For this method, a vacuum-tight, hermetically sealed piece of equipment is necessary.

3. Continuous flow purging – This is used for plants, machines, containers and any apparatus not laid out for internal pressure. In this process, inert gas is fed at one point in the system and released at another point away from the feed point.

The centrifuge systems discussed in this paper use a version of the third method, continuous flow purging. Multiple global standards guide the design requirements for machines where keeping the atmosphere out or the material inside a closed loop is imperative. The purged centrifuge systems discussed in this paper are built to Class I, Div. 1 [USA (NEC 500)] standards. In addition, these systems are also permitted within all Class 1, Div. 2 applications. These systems could also be designed for Canadian NEC 505 and are currently available for European ATEX Directive (2014/34/EU). There are different requirements for each. This paper, however, will focus on NEC 500 classifications.



There are three general application designs:

• **Oxidation** – *Protecting a product from the environment, e.g., oxidation in food processing.* Oxygen from the atmosphere may cause deterioration of the product by oxidation. To avoid this, the air within the centrifuge is replaced by an inert gas, forming a seal, which results in higher product quality when processing food, beverages, vegetable oils, etc.



• **Combustibles** – *Processing of flammable or explosive media.* Due to the risk of a spark occurring, it is necessary to create an inert atmosphere inside the centrifuge. This is accomplished by removing all combustible gases from inside the centrifuge during startup and maintaining an inert atmosphere during operation that allows the safe processing of combustible materials. Some examples of combustible media are:

- alcohols: methanol, ethanol, isopropanol, etc.
- solvents: hexane, heptane, octane, acetone, toluene, etc.

• **Hazardous** – *Processing of dangerous media.* The main focus here is to protect those within the environment (e.g., operators) from hazardous materials escaping out of the decanter centrifuge.



Zones and Divisions for Area Classification Explained



Zone 1 refers to an area in which an explosive atmosphere consisting of a mixture of air and dangerous substances in the form of gas, vapor or mist is likely to intermittently occur in normal operation. The class designations tell you what type of flammable or combustible materials are

present. Hazardous areas are classified into zones to facilitate the selection of appropriate mechanical/electrical apparatus, as well as the design of suitable mechanical/electrical installations.

A Class I, Div. 1 location is a location in which:

1. Ignitable concentrations of flammable gases or vapors can exist under normal operating conditions;
2. Ignitable concentrations of such gases or vapors may exist frequently because of repair or maintenance operations or because of leakage;
3. Breakdown of the equipment or a failure of the process might release ignitable concentrations of flammable gases or vapors and might also cause simultaneous failure of electrical equipment in such a way as to directly cause the electrical equipment to become a source of ignition.

(Source: National Electric Code Articles 500–504 [Divisions])

The Control Panel

A similar, but less complicated method of pre-purge and blanketing is also used to flush the control panel for the system if it is directly installed in the classified area.



Flottweg's Purged System Explained

A mathematical function calculates the volume of the centrifuge and the amount of gas that is required to displace the space. Once an adequate amount of volume has been displaced and safe operating conditions are reached, the system is considered to be in an operational state (i.e., inert). During operation, the differential pressures must be maintained to ensure safe operation. An overpressure sealing system consists of approximately five flow meters, two flow switches and eight pressure sensors.



Special mechanical shaft seals prevent the surrounding atmosphere from penetrating into the interior of the centrifuge and the escape of gases from the inside, assuming a steady overpressure. A seal consisting of several sealing rings separates the interior of the centrifuge from the outside atmosphere.

Inert gas is fed between the sealing rings. It flows through narrow seal openings, both into the interior and to the atmosphere. This is only possible if the pressure at the seal face is higher than the pressure in the decanter housing (> 0.290 PSI) and the outside atmosphere. The differential pressure (0.725–1.45 PSI) between the housing and the gas feed point is monitored and controlled. Seals are pressurized, keeping oxygen from entering the system.

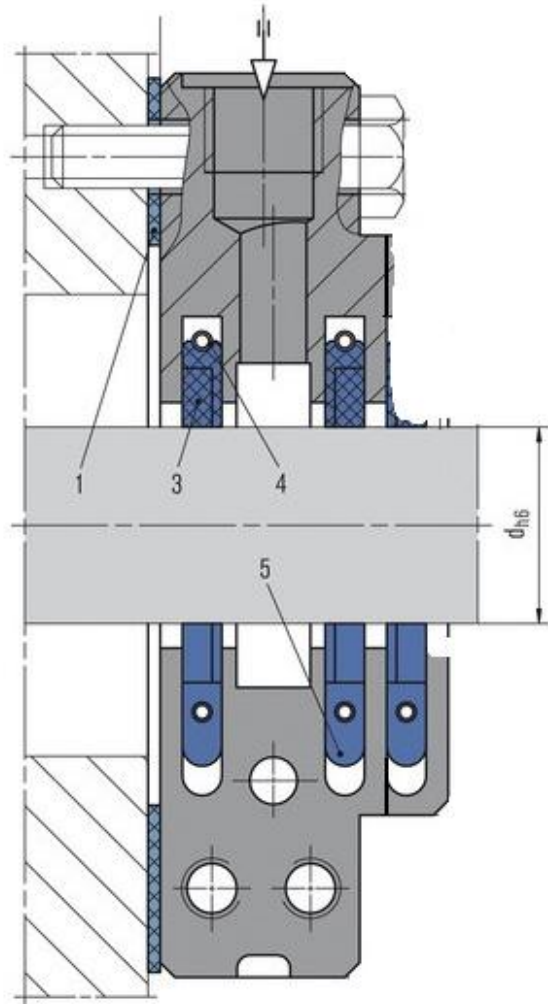

How Oxygen Monitoring Fits Into Flottweg's Sealing System



The oxygen sensing unit's function is to monitor the permitted oxygen concentration inside the centrifuge housing when processing products with readily combustible or explosive vapors (e.g., solvents). The only advantage to using these sensors is that they offer continuous oxygen monitoring. Implementing these sensors can prove beneficial if the differential pressure between the internal housing and the atmosphere is < 0.290 PSI. The list of disadvantages (essentially resulting in higher operating costs) of using oxygen sensors is much longer:

High installation costs; extensive PLC programming required; high maintenance effort (periodic calibrating transmitter with oxygen sensor); breakdown susceptibility; stress factors such as temperature, gas dosing and pollution reduce the life time of the sensor; and ONLY suitable for alcohols.

Calculating the oxygen displacement and using continuous flow purging with overpressure at the seals is a safe and effective method for processing in a Class I, Div. 1 area, which renders the oxygen sensors redundant and costly.

Continuous Flow Purging vs. Oxygen Monitoring



Both methods ensure safe operation if they are properly laid out, installed and maintained. Overall, however, continuous flow purging has better net positive usability when compared with oxygen monitoring to ensure safe operating condition.

Using oxygen monitoring as a measurement enables direct information about the risk factor of the oxygen concentration. The weak point is the oxygen sensor itself, which requires a high degree of calibration, periodic replacement and comprehensive maintenance.

Using overpressure is an indirect system. As long as the overpressure on the seals/housing is maintained, no oxygen from the environment can penetrate into the system. Therefore, the oxygen concentration is held below the critical level. To control all of this, only flow meters and pressure gauges are necessary, but both are easy to maintain.

However, since overpressure systems rely on pressure sensor set points, it is possible to cause erroneous system shutdowns in applications where lower differential pressures are used. An oxygen sensor allows for more sensitive monitoring of this danger zone.

In Conclusion

Using an inert gas to form a tightly sealed or purged centrifuge is an excellent solution for a variety of applications. These include: explosion protection in the chemical, pharmaceutical, petrochemical or biodiesel industries; oxidation prevention for food, beverage or cooking oils; and environmental protection from hazardous materials such as those generated during tar cleaning.

Centrifuges have higher throughput capabilities than filters or presses and operate as a continuous process, instead of batch systems like filters or presses.

When considering such a system, it is important to find a partner who will design one that follows all necessary safety measures and offers in-depth documentation and training.

Once commissioned, continual inspection plans should be followed to check the tightness of the purge unit. A leak tightness test schedule should be generated and performed regularly. Test points are screw connections, manometers, flow meters and hoses. Supply lines also must be checked at regular intervals for damages, clogging and tightness.

The centrifuge machine itself should also be regularly maintained. These standards should be defined by the manufacturer of the centrifuge, but actual servicing schedules should be defined by the operator. Separating two phases, three phases or a very light emulsion with a purged centrifuge (e.g., decanter, Tricanter or separator) is certainly possible; however, there are some design variations among these centrifuges that should be considered.

Additional Information

Redundancy – The inert gas supply system must be equipped with sufficient buffer or redundancy to guarantee the continuous consumption of the plant during centrifuge downtime in case of any failure.

Technical requirements for the inert gas (nitrogen [N₂])

- Inlet pressure: 4–6 bar (g)
- Purity level from the inert gas: min. 99 vol % N₂ (max. 1 vol % O₂)
- Filtration degree: 5 µm
- Inert gas temperature: 0–60°C
- Moisture content from the inert gas:
 - pressure dew point ≤ 3°C at temperatures above 3°C
 - pressure dew point ≤ -20°C at temperatures below 3°C

Technically tight vs. hermetically sealed – A hermetically tight piece of equipment provides a zero-leakage tolerance, whereas the tightness in technically tight systems cannot be ensured permanently due to design, function, etc.

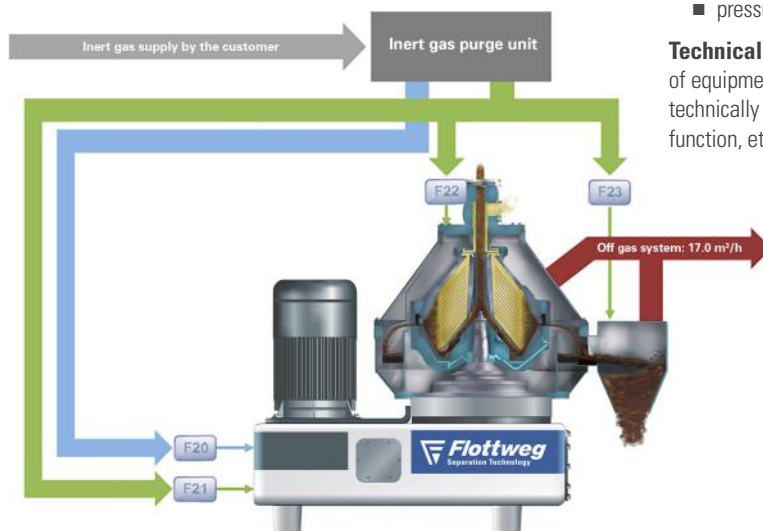

Flottweg Separation Technology, Inc.
10700 Toebben Drive
Independence, KY 41051

Telephone: (859) 448-2300
Fax: (859) 448-2333
Email: sales@flottweg.net Flottweg.com

Member of the Flottweg Group